

Product Dimensions

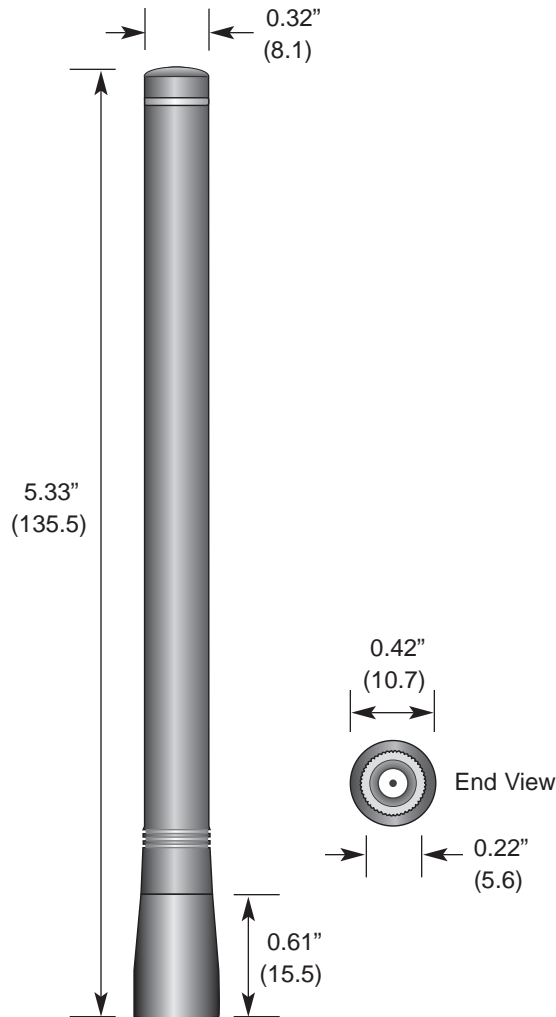

Description

HW Series 1/2-wave center-fed dipole antennas deliver outstanding performance in a rugged and cosmetically attractive package. The antenna's internal counterpoise eliminates external ground plane dependence and maximizes performance. HW Series antennas attach via a Part 15 compliant RP-SMA connector. Custom colors and connectors are available for volume OEM customers.

Features

- Low cost
- Internal counterpoise
- Excellent performance
- Omni-directional pattern
- Outstanding VSWR
- Rugged & damage-resistant
- Part 15 compliant RP-SMA connector

Electrical Specifications

- Center Freq. 868MHz
- Bandwidth 25MHz
- Wavelength 1/2-wave
- VSWR <1.9 typ. at center
- Impedance 50 ohms
- Gain -1.63dBi
- Connector RP-SMA

Electrical specifications and plots measured on 4.00" x 4.00" reference ground plane

Ordering Information

- ANT-868-CW-HW

Polar Plots and VSWR Graph

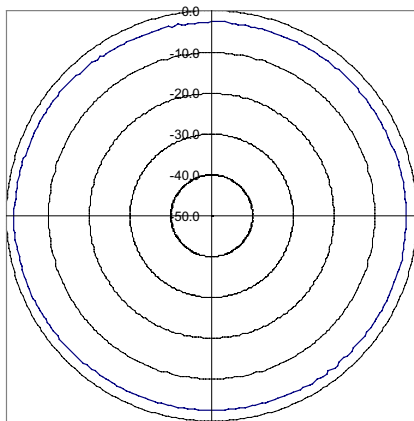

Azimuth

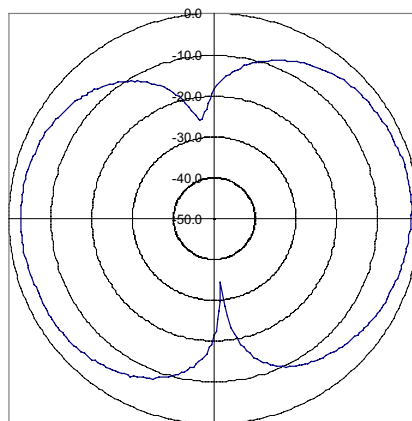

Elevation

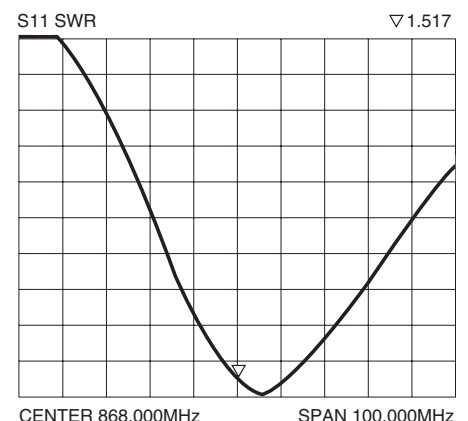

Typical VSWR



Azimuth Radiation Pattern

Measurement Antenna Polarity: Vertical
 Test Antenna Polarity: Vertical
 Maximum Absolute Gain: -1.83dBi

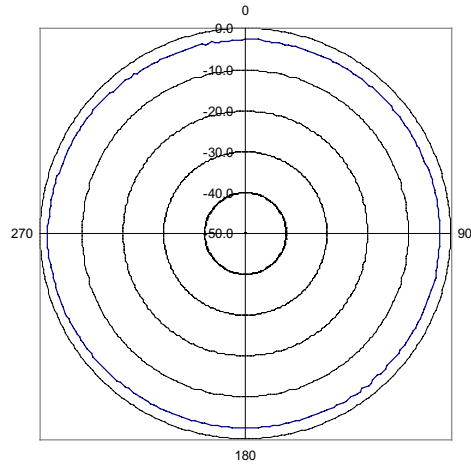
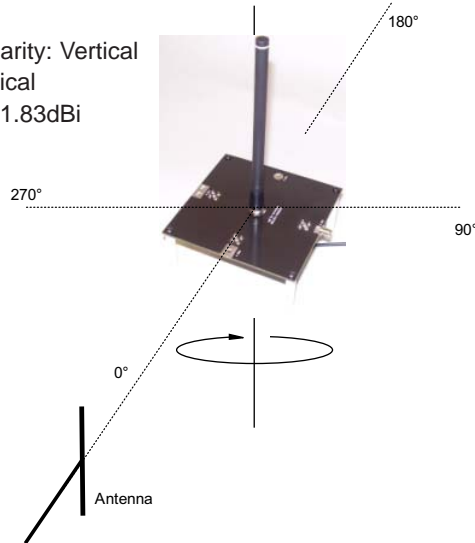

Elevation Radiation Pattern

Measurement Antenna Polarity: Horizontal
 Test Antenna Polarity: Horizontal
 Maximum Absolute Gain: -1.63dBi

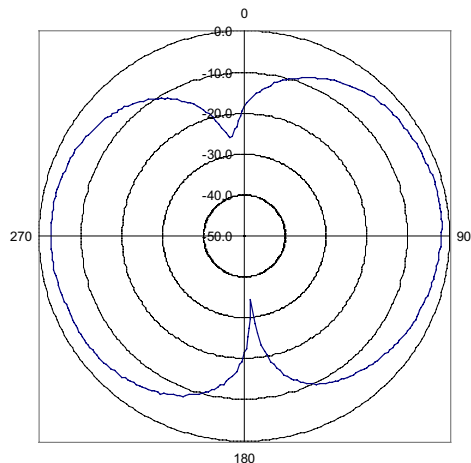
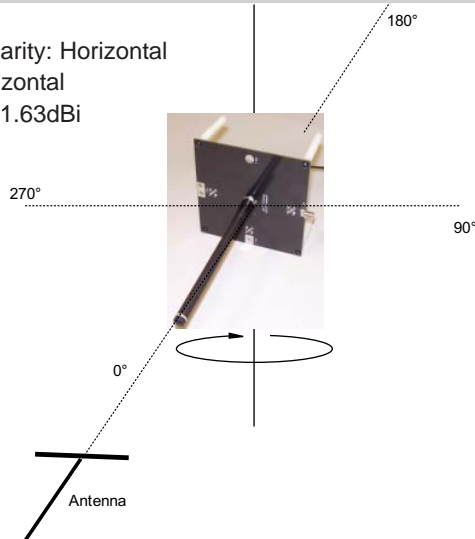

Antenna Test Fixture

ABOUT THIS TEST FIXTURE

The adjoining diagram shows the dimensions of the fixture on which the stated pattern and gain measurements were made. This does not mean that your product must conform to this size or antenna orientation, although it should be recognized that the gain, pattern, and performance may increase or decrease accordingly. Antenna Factor recognizes that our antennas are often used in compact applications with less than ideal ground planes. In some cases, the reference jig is smaller than optimum, particularly with lower-frequency antennas. This is, in part, to more accurately reflect the performance of the antenna in typical real-world applications.

