

Product Dimensions

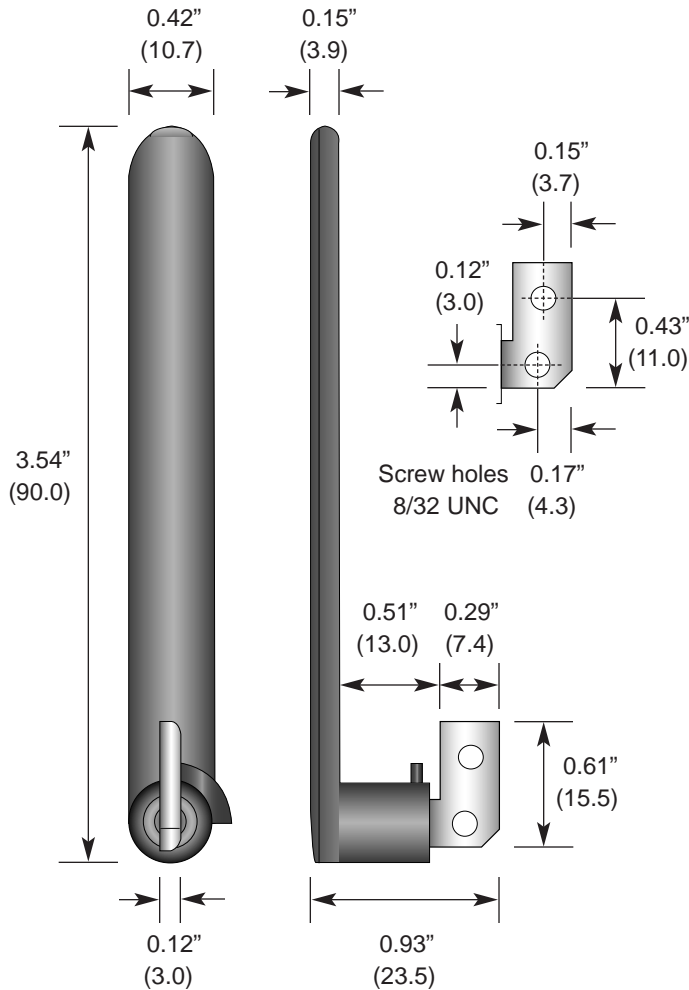

Description



PMB Series antennas combine a soft blade-type element with a rugged package that is resistant to damage and abuse. The antenna features a molded tab that allows coding of the product's enclosure to control 360-degree rotational travel. The PMB mounts to a PCB via one or two screws and meets Part 15 requirements.

Features

- Low cost
- Soft blade-type element
- Rotates 360 degrees
- Omni-directional pattern
- Weather resistant
- Flexible main shaft
- Damage resistant
- Screw-mount

Electrical Specifications

- Center Freq. 916MHz
- Bandwidth 200MHz
- Wavelength 1/4-wave
- VSWR <2 typ. at center
- Impedance 50 ohms
- Connection Screw-mount

Electrical specifications and plots measured on 4.00" x 4.00" reference ground plane

Ordering Information

- ANT-916-PMB

VSWR Graph

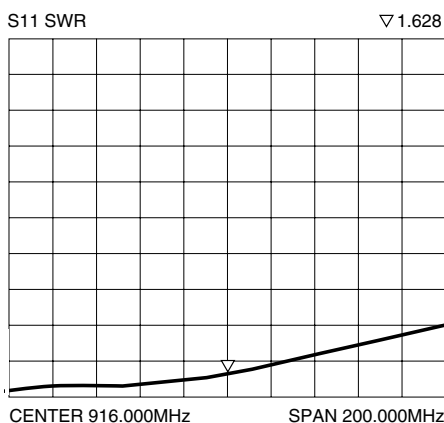

Typical VSWR

Polar Plot & Gain Information

Monopole antenna gain and radiation patterns are dependant on the ground plane and layout of the end product. Since antenna manufacturers do not measure on standardized ground references, comparison of published specifications is an unreliable indication of actual antenna performance in an end product. Optimum full-wave ground planes are impractical for the majority of products on which these antennas are used (the ground plane for 916MHz would be 26.5" in diameter, 418MHz would be 56.5" in diameter). For this reason, Antenna Factor tests and tunes antennas on reduced-size, compromised ground planes. To avoid mis-comparison or inappropriate application, gain and polar plots do not appear on this data sheet, but are available upon request for most products.